

**JOHN DEERE
744H
INSTALLATION INSTRUCTIONS**

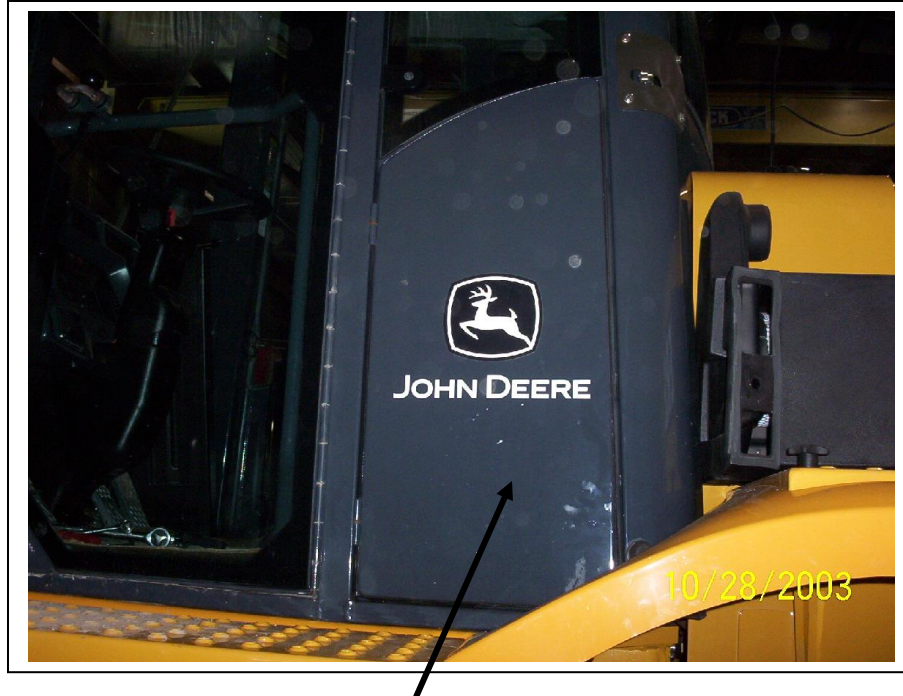

**PHONE: 1-800-267-2665
FAX: 1-888-267-3745**

EVAPORATOR



Open this door(latch inside the cab on left beside the seat) and remove the filter assemblies to expose the fitting end of the heater box.

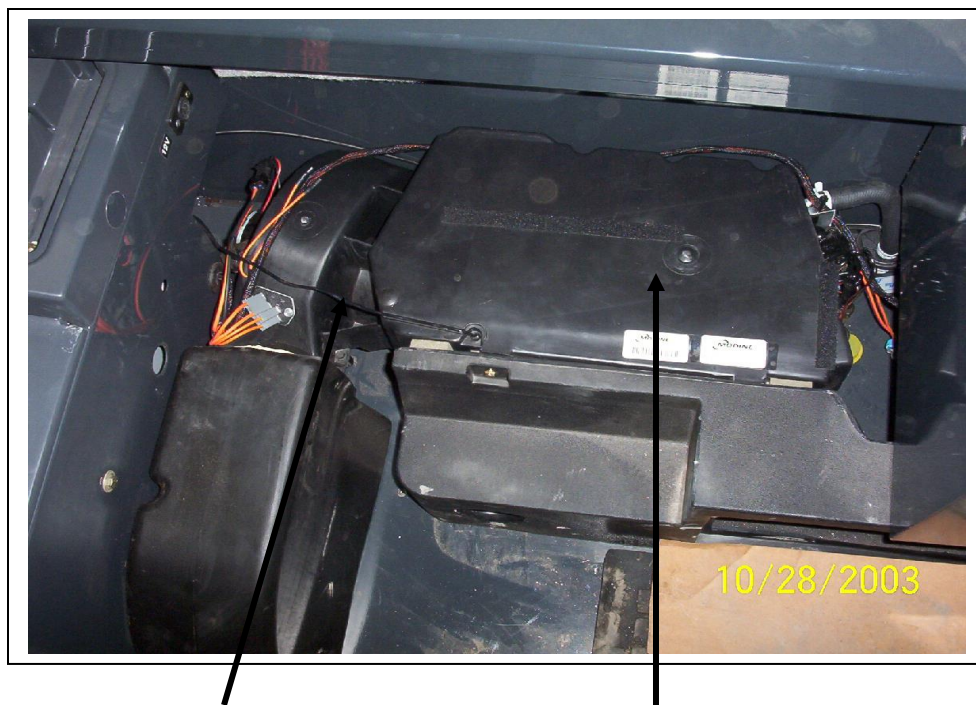

Thermostat probe

Heater A/C box behind seat

Remove seat and remove plastic covers and trays from behind the seat to expose heater box.

When re- installing the box lid run the thermostat probe through the existing hole and into the evaporator coil.

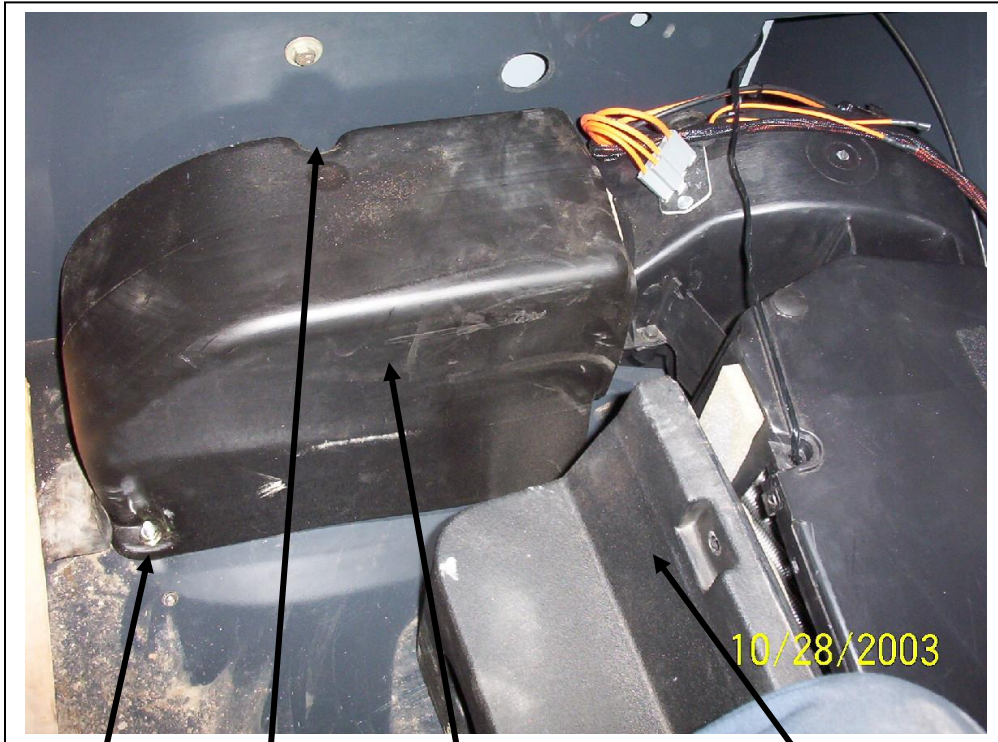

1st bolt

2nd bolt down
behind here

Remove this air
outlet channel

Unbolt the inside air intake channel
and pull it away from the heater as
shown.

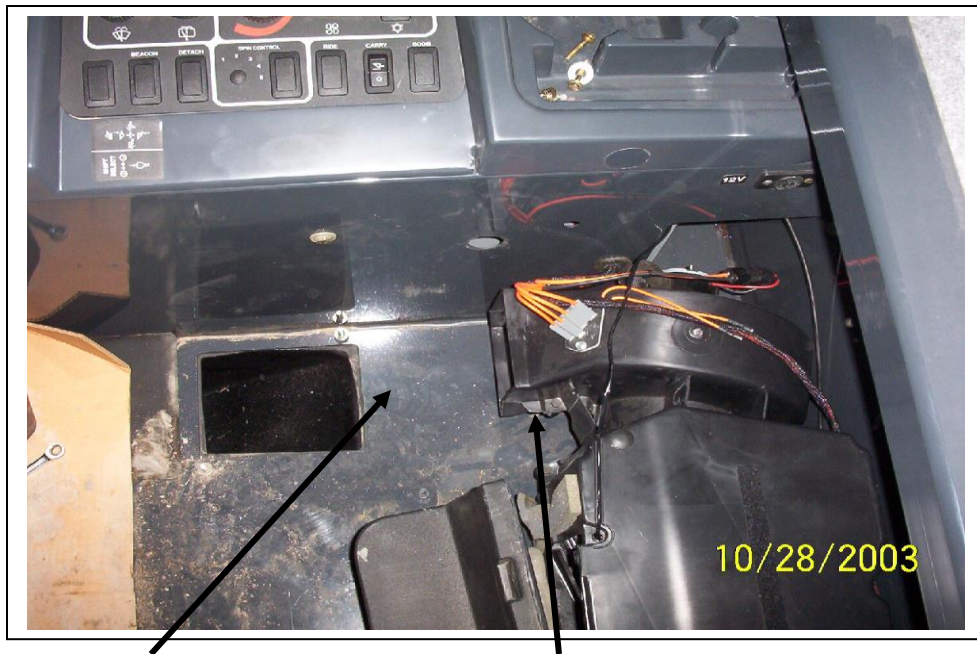

Air outlet channel removed

Remove all bolts holding the top half of the heater box on. Don't forget the two upper bolts on the blower motor flange.



Top half of heater box removed. Top half of blower housing is part of the same assembly.

Heater coil

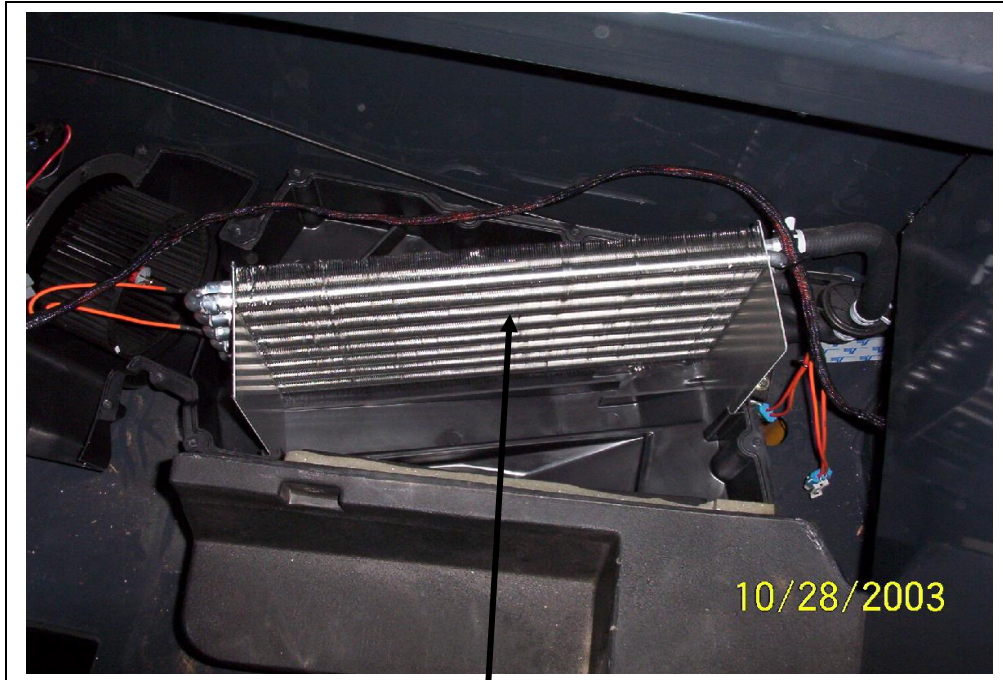

Heater coil

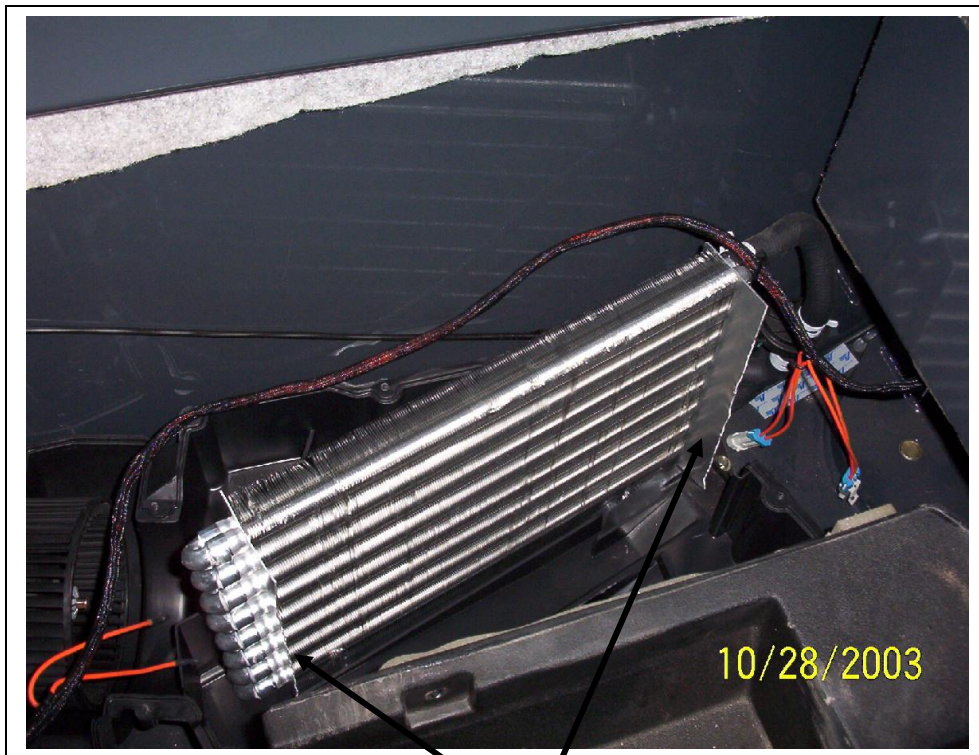

Cut existing aluminum flanges down to about 1" using metal snips



Lift heater coil and remove drain plug. Glue in the copper drain extension supplied in the kit. Use 5 min epoxy

Bend both heater flanges over flush with the coil fins. Being aluminum they bend quite easily.



Insert the evaporator coil in the heater box beside the heater coil as shown.

COMPRESSOR

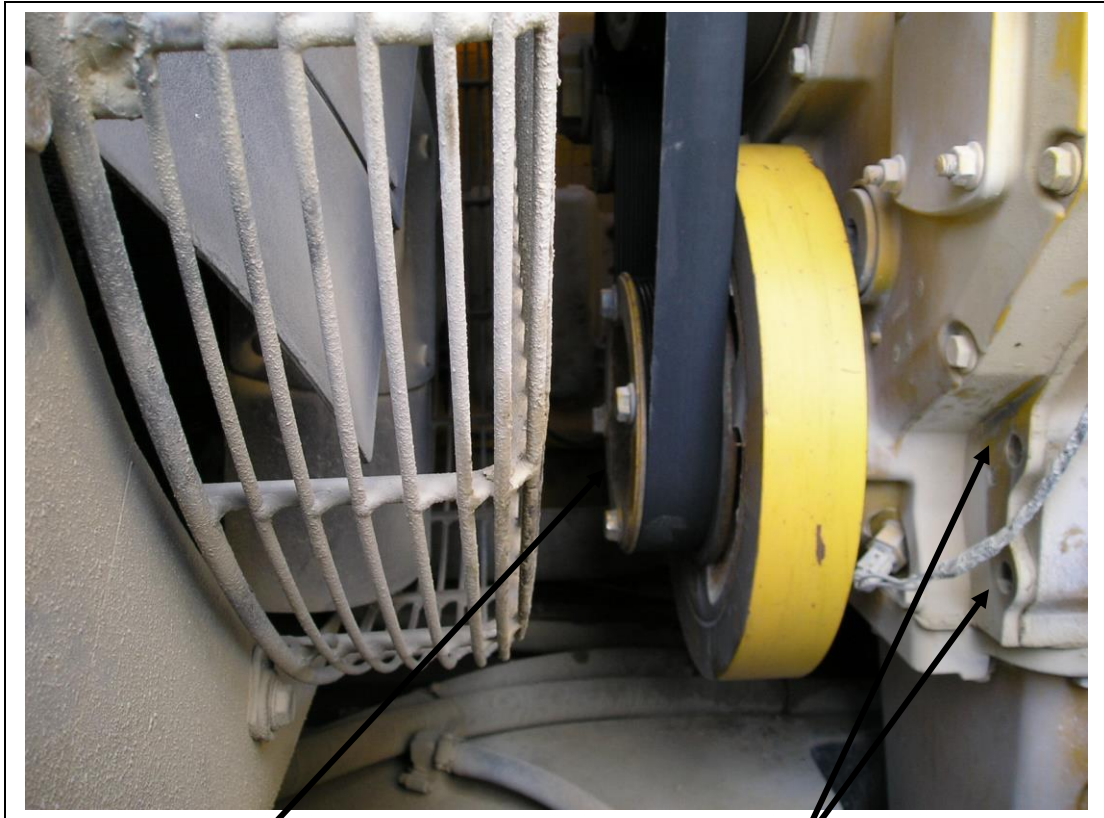

Bolt pulley on here

Bolt mount on here using M16 x 45
MM bolts.

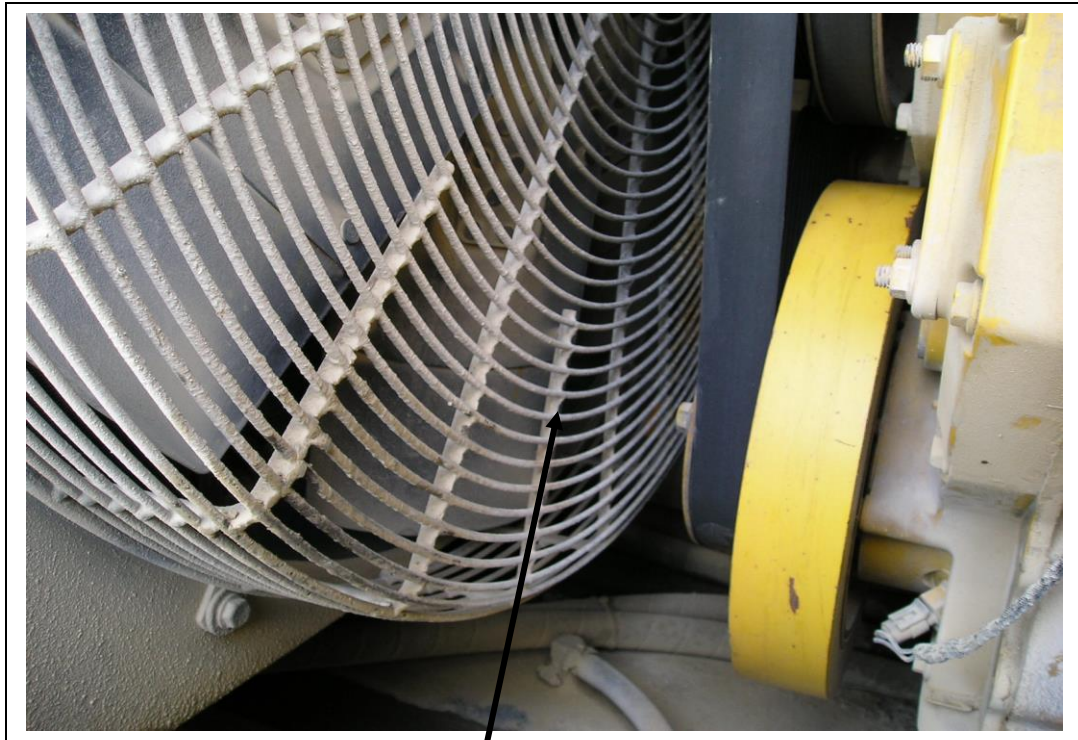

Cut out one piece of wire from the fan screen to allow the crank bolts to
be removed.

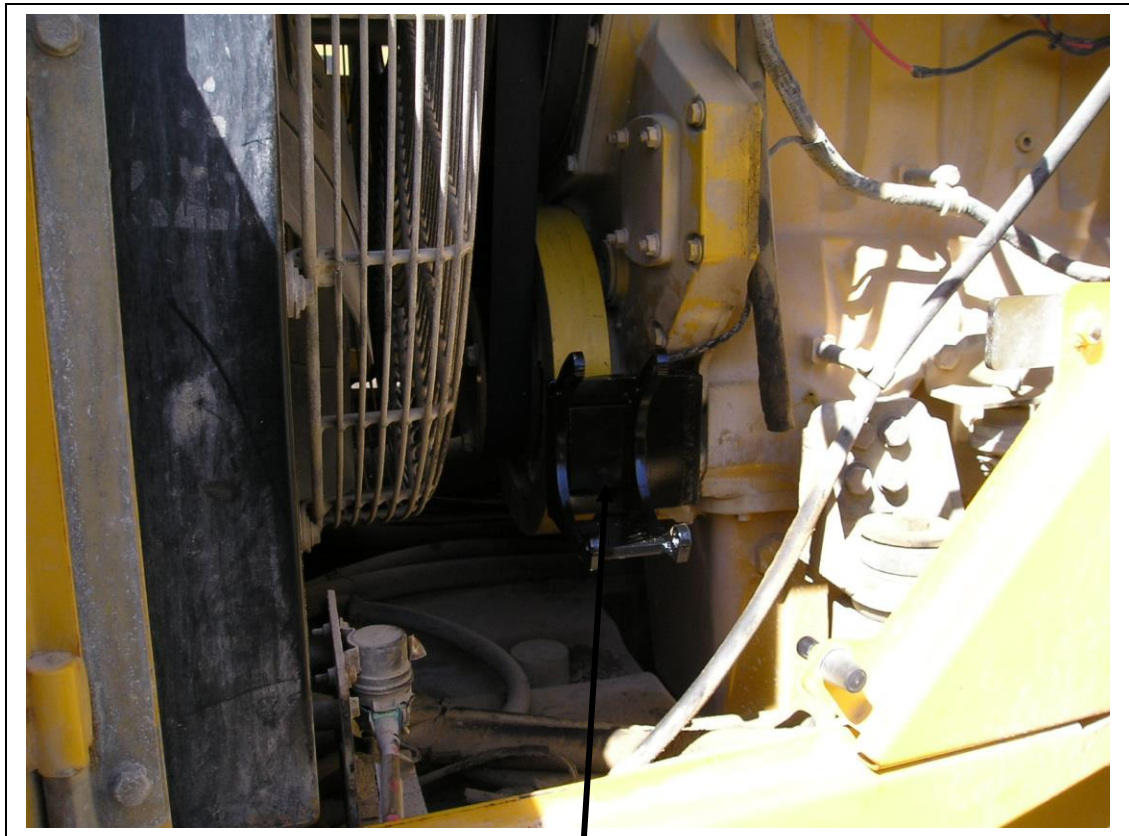

Compressor mount bolted to engine



Pulley bolts onto the crank using longer M12 bolts in place of the original bolts.

To mount the pulley, one piece of the fan screen wire needs to be cut out so the bolts of the crank pulley can be removed and longer ones installed.



Belt on compressor and on crank pulley.

Compressor in place on mount.

CONDENSER

The 16" x 24" condenser mounts to the fan screen above the fan hub. The condenser mounts to the fan screen with the supplied spin lock bars. The fittings need to be on the right side of the machine with the 13/32" fitting on the top.

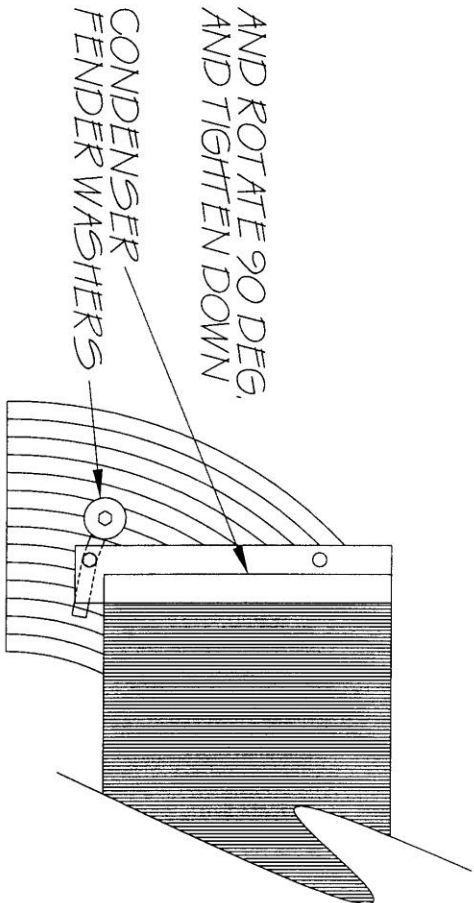
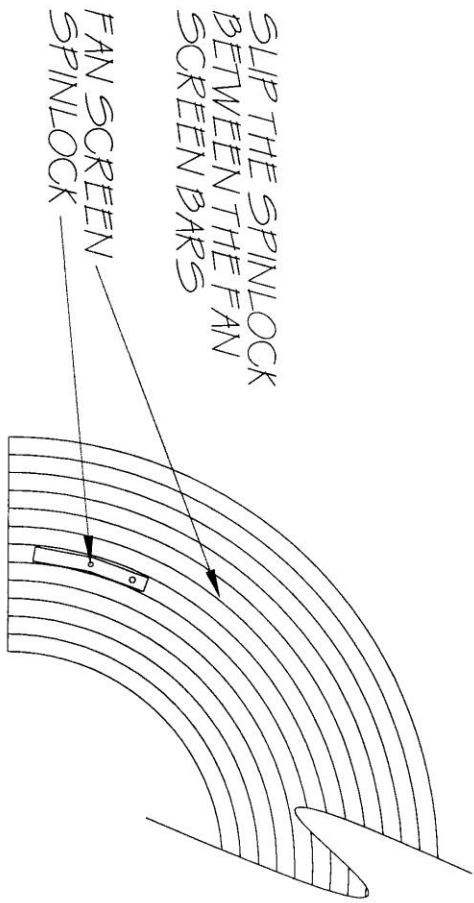

DRAWING TITLE:	
SPINLOCK INFO.	
DRAWN BY:	J.S.
APPROVED BY:	J.L.
MODIFIED ON:	MAR. 15, 2002
REV.:	0
UNITS:	S.A.E.

RECEIVER DRIER

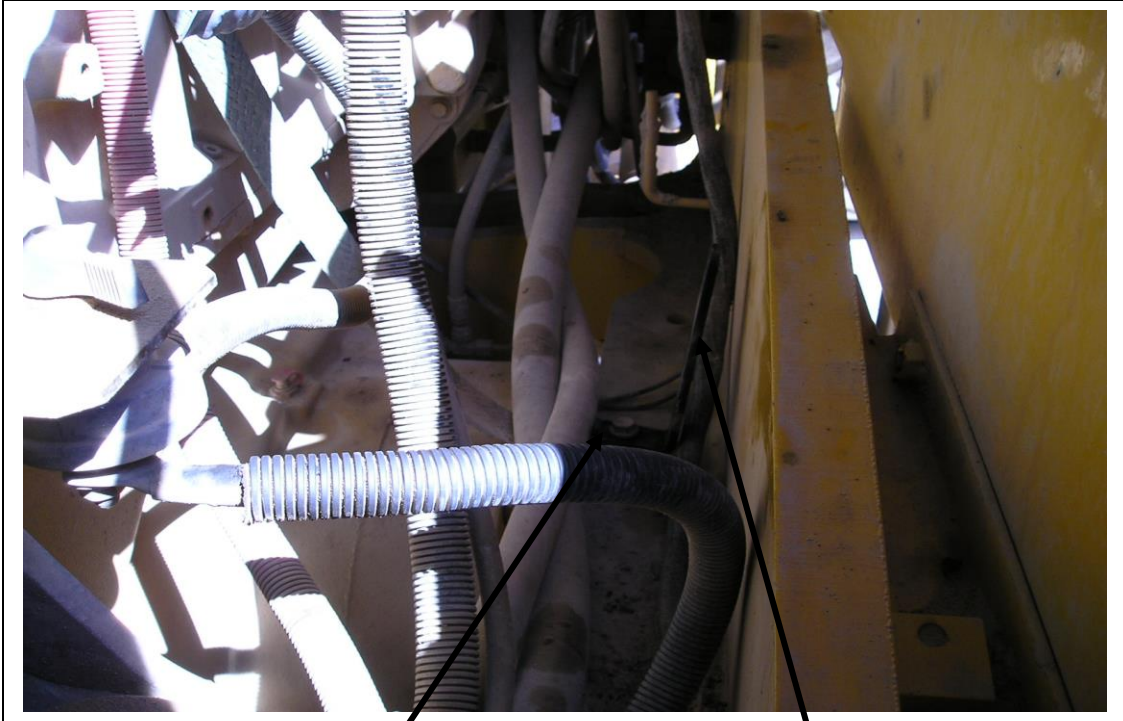

Drier bracket mount bolt location.

Drier bracket

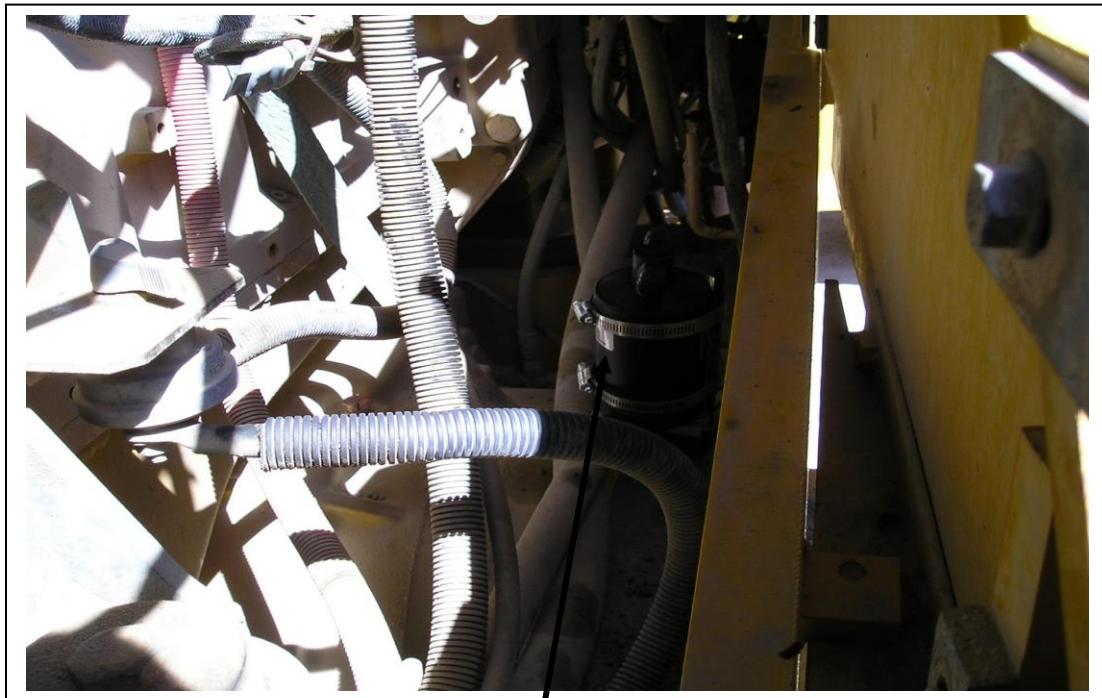

Receiver drier attached to mount bracket.

HOSE RUNS



5/16" and 1/2" hoses under the cab looping up towards the existing knockouts in the cab floor on the left side of the cab.



5/16" line going up into the cab.

1/2" line going up into the cab.



1/2" line connected to the evaporator outlet.

5/16" line connected to the expansion valve.

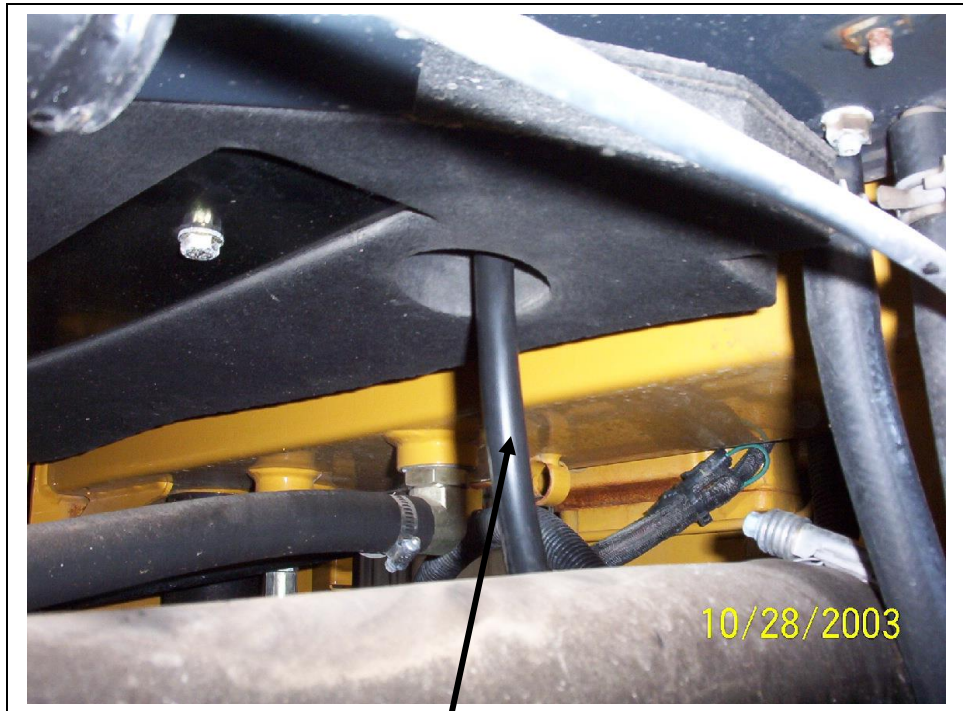

Drain tube and restrictor installed under the cab on the drain outlet.

ELECTRICAL



Mount the thermostat in the existing rectangular hole to the right of the blower switch. Use the supplied fender washer to cover the hole and mount the temp decal.



Remove about 48" of the clutch wire from the loom and feed it up through the main wire harness grommet on the right side of the cab.

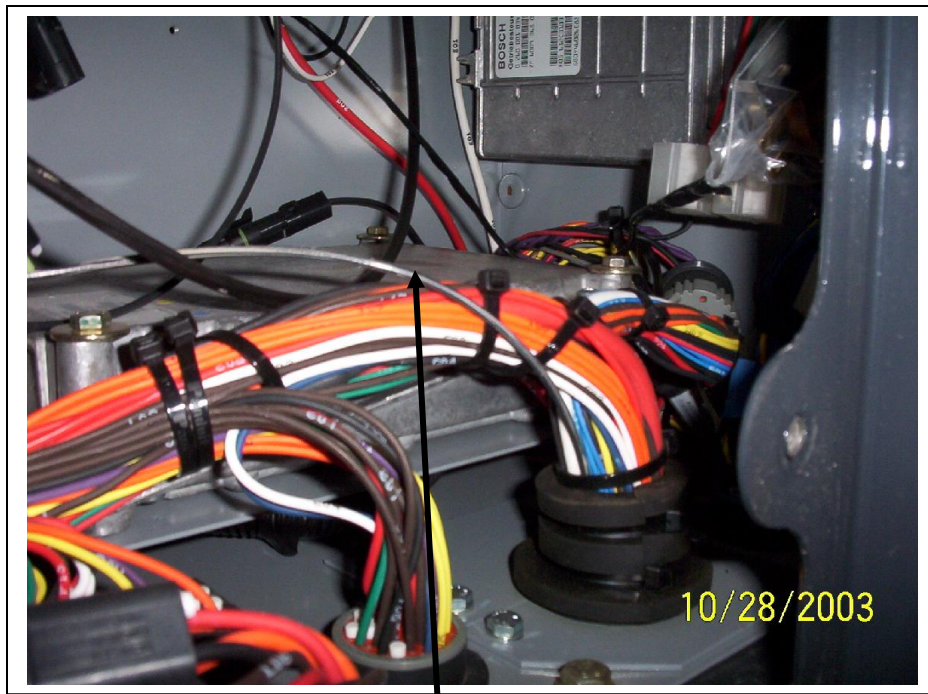

14 gauge black clutch wire coming up into the electrical area on the right side of the cab.



Clutch wire with loom re-installed running up the wire bundle towards the thermostat.

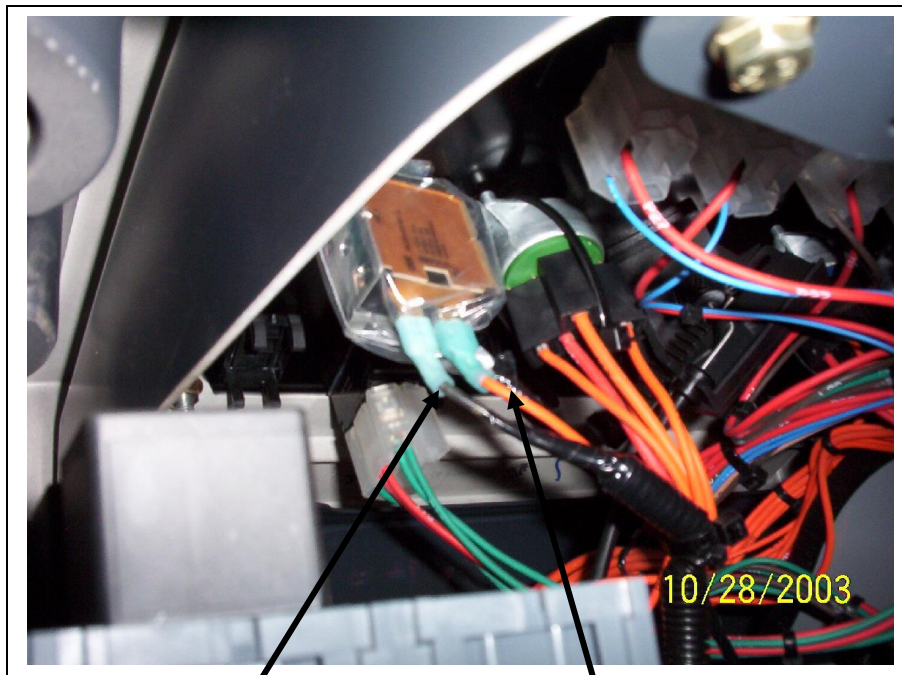

Plug the black 14 gauge clutch wire into the thermostat.

Find the clutch wire coming off the blower switch and cut it out of the wire bundle at least 6" long. Crimp on a female connector and plug it into the thermostat.



From the bottom of the cab run the clutch wire back towards the engine along with the suction hose and connect it to the binary switch at the compressor.

Refrigerant Flow Pattern in a Standard Air Conditioning System

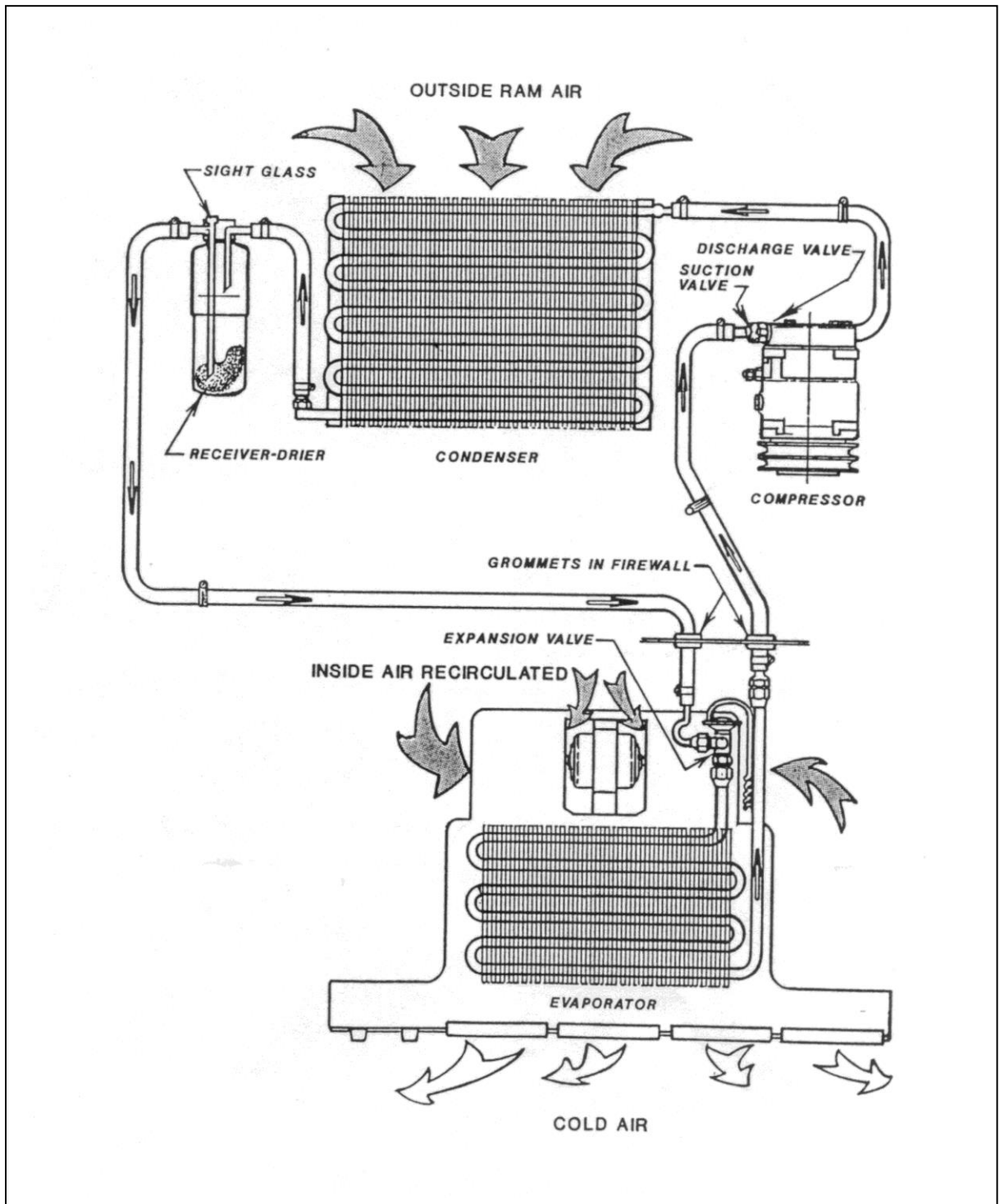

Final checks and charging:

1. Pressure test the system with nitrogen to at least 250 PSI and check all fitting and connections for leaks. The complete electrical system can be tested while there is pressure in the system as well.
2. Vacuum the system out with a good vacuum pump for ½ hour to 45 minutes. Ensure the system holds a vacuum to double check it for leaks. Add 4 oz of PAG oil to the system. Charge the system with 3 lbs of new 134A refrigerant. Run the system to test it. Check the temperature at the louvers. Add 134A refrigerant in 2 oz increments and check the air temp. A charge of 2 AND ¾ lbs should be about right.
3. Check that the thermostat is cycling the compressor off before coil freeze up problems can occur. The thermostat can be adjusted with the adjustment screw under the plastic cap on the body of the thermostat. See the thermostat setting procedures at the end of this instruction manual.

Thermostat Setting Procedures

- 1) Thermostat types
 - a) preset
 - b) adjustable
- a) A preset thermostat is adjusted to its specific cut in and cut out temperatures when manufactured and does not have a rotary adjustment for the operator.
- b) An adjustable or rotary thermostat has been manufactured to a predetermined cut in and cut out temperatures, but it is also operator adjustable to achieve the desired comfort level.

Both types of thermostats can have their factory settings adjusted by turning the setting screws on the body of the thermostat. One body type has the setting screws mounted externally and labeled for direction of rotation. The other body type requires the removal of the plastic end plate to expose the set screw.

- 1) Thermostat probe location: The location of the thermostat probe in an evaporator coil can be very important to achieve the maximum cooling potential of the coil while also preventing coil freeze-up. There is no set location for the thermostat probe to be put that will be optimum for all systems, but several rules of thumb may be followed:
 - a) Insert the probe in the coldest area of the evaporator coil.
 - b) Insert the probe from the top of the coil down, if possible.
 - c) Make sure that at least the last 3" of the thermostat probe are in the coil.

To find the most likely area where the coil is the coldest, consider these factors:

1. Direction of the air flow through the coil.
2. The coil area likely to have the lowest air flow.
3. The inlet locations of the refrigerant into the coil.
4. The inlet of the hotter outside air into the coil area.
5. Usually the coldest side of the evaporator coil will be the air outlet side. Often the thermostat probe can be inserted between the last and second last row of tubes.
6. The lower air flow area of the evaporator coil in most systems tends to be near either end of the coil. These areas will be colder
7. The area of the coil that the refrigerant inlet tube(s) occupy should be the coldest part of the coil.
8. If the system is equipped with an outside air intake, where and how that air is brought into the evaporator area can have a large effect on the coil temperature. If all the outside air is piped into the evaporator in one area, that area will be considerably warmer in hot weather.

By looking at all these different factors, the area of an evaporator coil most likely to be the coldest can be determined.

Once the probe is inserted, the A/C system needs to be tested. Run the system to ensure that the thermostat is cycling the compressor off at the appropriate temperature. A core temperature ranging between 25° and 30° F should cause the thermostat to cycle off. The air temperature at the vent outlet closest to the evaporator coil should be between 38° F and 45° F when the compressor cycles off.

If the thermostat doesn't cycle off after a reasonable cool down period, and the air outlet temperature has dropped below 40° F, the cut in and cut out settings should be adjusted until the compressor is cycling on and off regularly. Let the system run for a decent time period (at least 15 min) and then check the evaporator coil for any signs of freezing.

Aeroquip E-Z Clip Assembly Instructions

Step 1. Cut the hose to proper length with an appropriate cutting tool. Aeroquip's hand held hose cutter has been specially designed for cutting all non-wire reinforced hose, such as GH-134 Multi-Refrigerant hose. Be sure the cut is made square to the hose length.

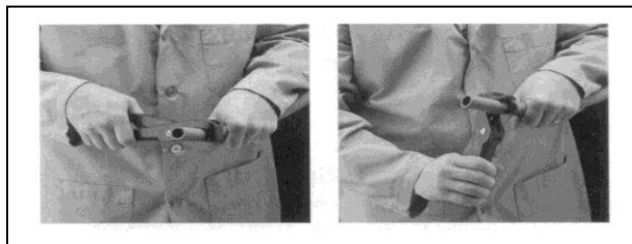

Step 2. Install two proper-sized clips onto the cut end of the hose. Orientation of the clips does not affect the performance of the connection. However, for ease of assembly, both clips should have the same orientation. NOTE: Failure to slide the clips over the hose at this time will require the clips to be stretched over the hose or fitting later. This may permanently damage the clip.

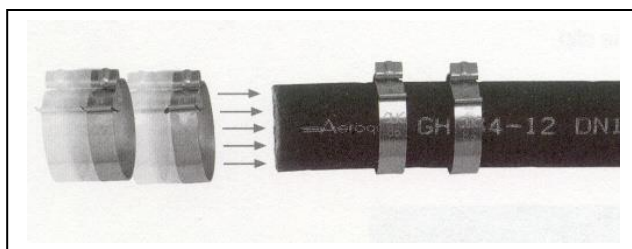

Step 3. Lubricate the nipple with a generous amount of the refrigeration or A/C system's compressor lubricating oil. This MUST be done to lower the force of nipple insertion.

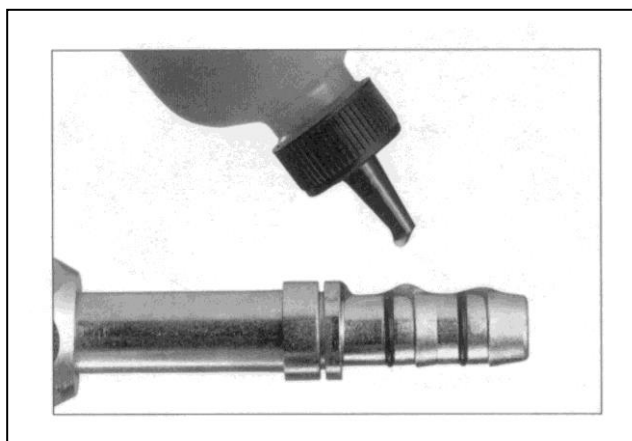

Step 4. Insert the nipple into the hose. To ensure that the nipple is fully inserted, check the gap between the cut end of the hose and the shoulder on the nipple. Care should be taken to avoid kinking or other damage to the hose during nipple insertion.

NOTE: Be sure to wipe excess oil from the nipple and hose.



Step 5. Snap the cage into the groove on the nipple. The arms should extend over the hose length. When the cage has been correctly installed in the cage groove, the cage will be able to rotate in the groove. This step **MUST** be performed to ensure:

1. The clips will be located over the O-rings on the nipple.
2. The connection will be compatible with the connection's pressure rating.

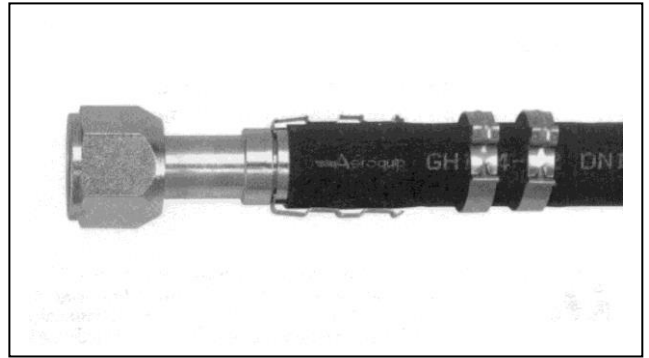

Step 6. Slide the clips over the cage arms and into the channels on each arm.

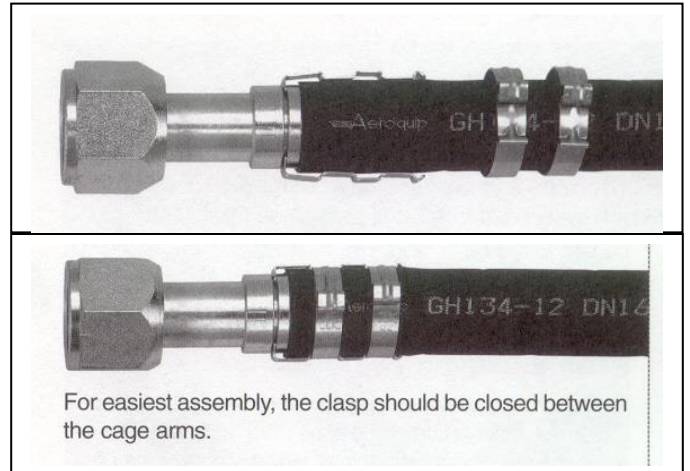

Step 7. Use the pliers to close the clips. The pliers should be positioned squarely on the clip connection points and should remain square during the closing of the clip.

NOTICE: E-Z Clip components should not be reused.

